



## High Flow Hydraulic diaphragm Chemical Pumps

Hot selling quality High Flow Hydraulic diaphragm Chemical Pumps Manufacturers and Suppliers. High Flow Hydraulic diaphragm Chemical Pumps that transmits power using operating oil (silicone oil, etc.) filled between a diaphragm and a piston that serves as the drive source.

A built-in relief (safety) mechanism eliminates the need for relief valves and other devices for handling abnormal pressure, making High Flow Hydraulic diaphragm Chemical Pumps effective for use with fluids that should not be exposed to outside air.

**Hot selling quality High Flow Hydraulic diaphragm Chemical Pumps Manufacturers and Suppliers.**

### 1.Product Introduction of High Flow Hydraulic diaphragm Chemical Pumps

High Flow Hydraulic diaphragm Chemical Pump consists of three main devices: (1) driving device, (2) adjusting device, (3) liquid delivery device. The crankshaft which reduces motor rotation speed by worm and worm gear makes the piston reciprocate in the hydraulic oil chamber. This reciprocating movements of the piston make the PTFE diaphragm and the liquid which is isolated by the diaphragm sucked and discharged. Each pump is with internal pressure relief valve protecting pump from over pressure conditions.

The flow rate can be adjusted via unique adjusting mechanism from 0-100%. The adjustment can be carried when pump is in operation or at stop. The steady state accuracy is  $\pm 1\%$  from 30%-100% of the maximum output. Automatic operation is achieved by variable speed drive.

Double diaphragm with diaphragm rupture detecting system is available to prevent accident caused by mixture of hydraulic oil and the liquid after diaphragm ruptures.

### 2.Product Parameter (Specification) of High Flow Hydraulic diaphragm Chemical Pumps

◆ Single-joint maximum flow: 10000 L/h ◆ Maximum discharge pressure: 24MPa ◆ Steady state accuracy:  $\pm 1\%$  ◆ Media Viscosity: 0-800mm<sup>2</sup>/s ◆ Temperature of transporting media can reach

over 150°C Power Supply: 380V 3 phase on standard, single phase or other voltage on request;  
EX-proof motor is available on request.

### **3.Product Feature And Application of High Flow Hydraulic diaphragm Chemical Pumps**

#### Feature

- Integrated "Oude" worn gear pair, low noise & high transmission torque.
- Built-in relief valve, compensating valve & limit valve
- Single or double diaphragm (PTFE or Metallic)
- Diaphragm rupture disc for alarm.
- Multi head in parallel connection for same fluid or multi fluids.

#### Application

##### Oil & Gas:

- Hydrogen Sulfide & Co 2 injection
- Glycol or Methanol injection
- Closed Drain Pump
- Injection of corrosion inhibitors

##### Refineries & Petrochemicals:

- Chemical Injection
- Amine treatment
- Polyethylene production
- Gas odorization

##### Power plant & water treatment plant

- Chemical injection

### **4.Deliver,Shipping And Serving of High Flow Hydraulic diaphragm Chemical Pumps**

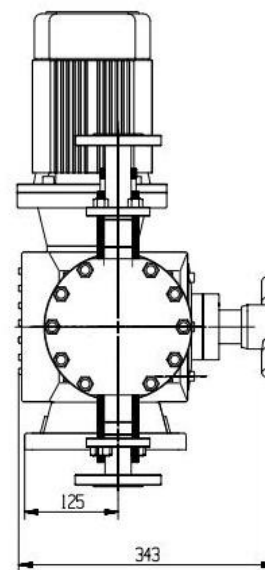
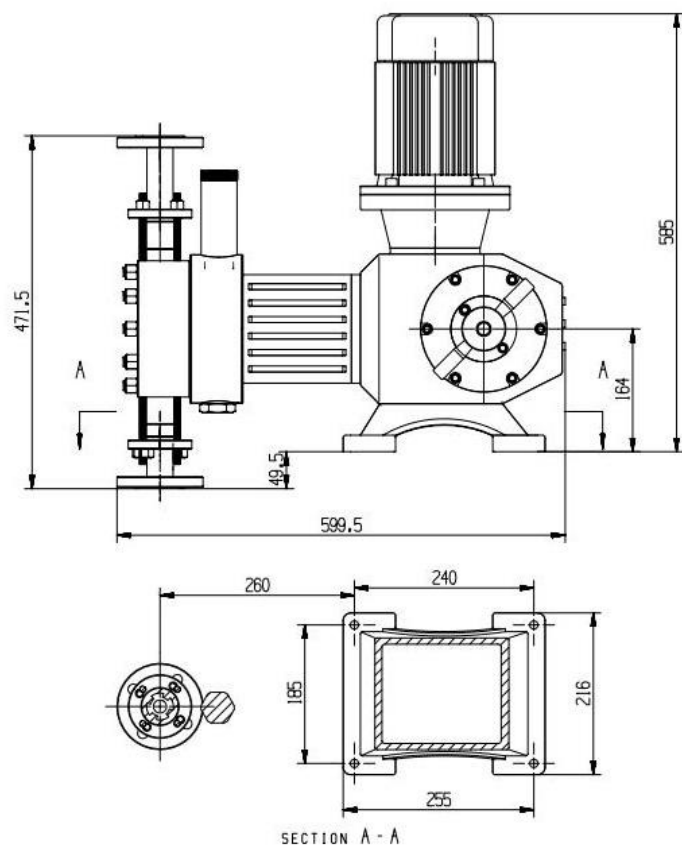

- 1、泵配电机：1.5kW，电机型号YBD2-90L-4
- 2、泵配法兰：DN25
- 3、过流材质：304
- 4、泵安装基础，水泥地面，地脚螺栓M10

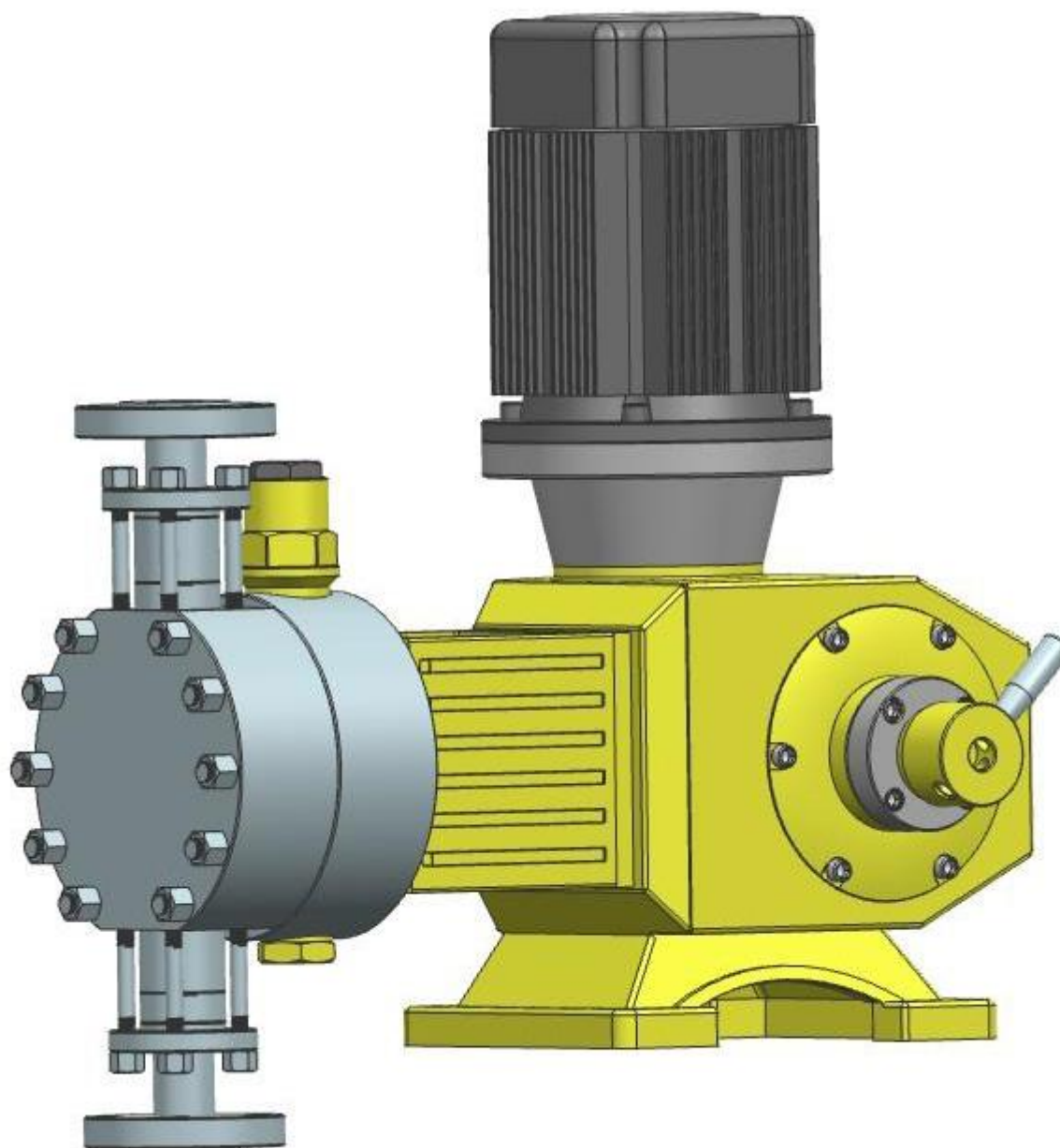

## 5.FAQ

Where are your products used?

Our pumps are widely used in different fields:water treatment,chemical processing,petrochemical industry,food industry, water plants,pharmaceutical industry and so on.



If OEM is acceptable?

We accept OEM.

Do you provide sample? Free or charge?

Samples require fees.

[www.cndkby.com](http://www.cndkby.com)